

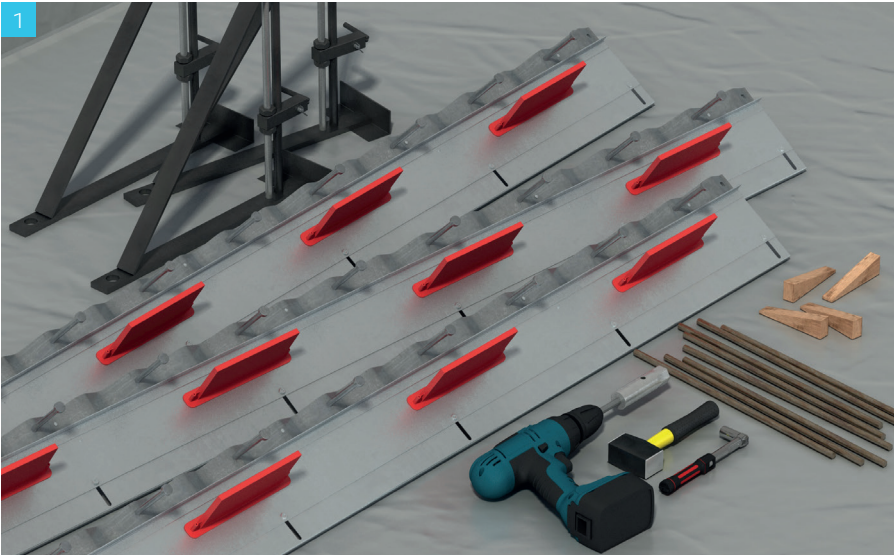

## Installation Guide

### ProGuardJoint



Set up laser dumpy level on-site, ensuring you have finished floor level (FFL) datum and relevant hand tools available. Ensure sub-base has been correctly prepared and relevant membranes placed.

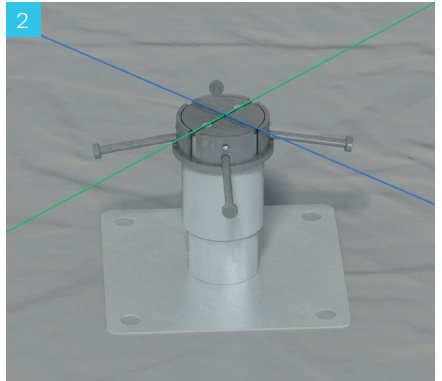

Set up string lines along the joint lines at the finished floor level.

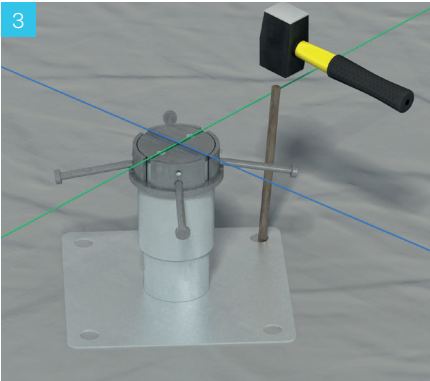

Position the intersection post and pin in place. Remove the cap and use the internal adjustment bolt for height adjustment. Adjust height ensuring cap surface is level with the finished floor level.

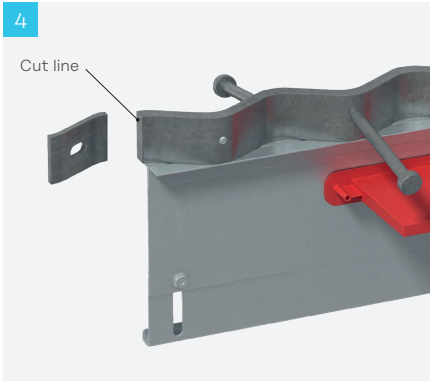

Cut the end of the first ProGuardJoint, ensuring it is square, to butt up against the intersection post.

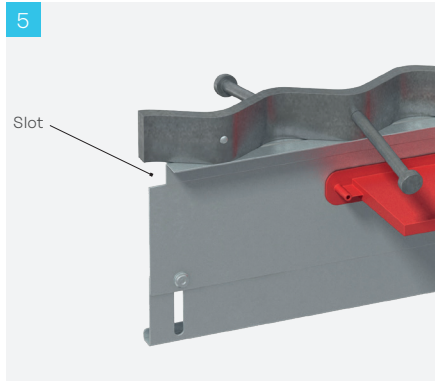

Cut away a slot for the ring on the intersection post and fold back to the fixed side of the joint (non sleeve side) or remove completely.

# Installation Guide

## ProGuardJoint

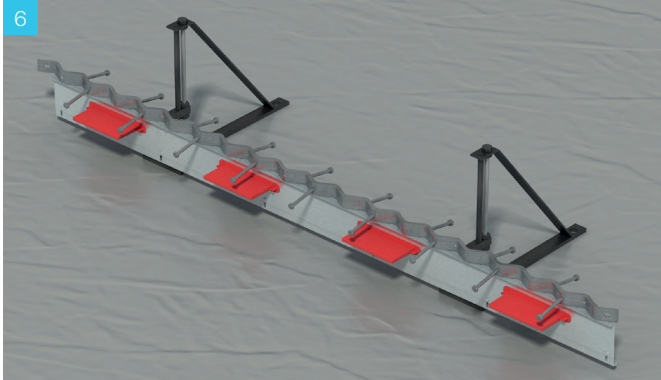

6 Fit ArmourFix jacks to the ProGuardJoint with ProGuardJoint jack fittings (these can be ordered separately).

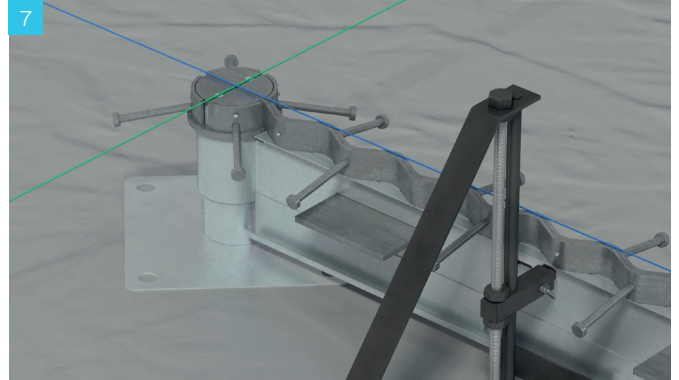

7 Position ProGuardJoint with jacks fitted up against the intersection post. Ensure the cut end is fitted up against the intersection post.

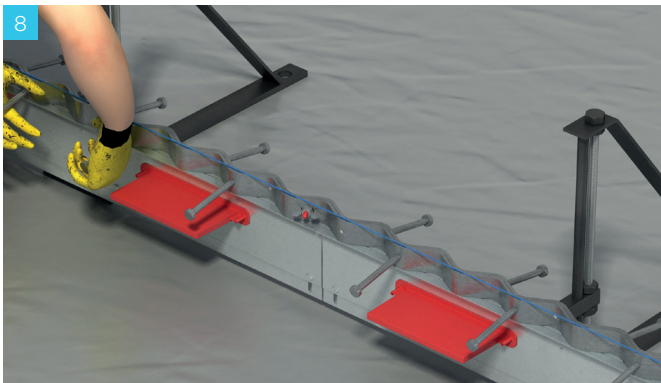

8 Continue to fit the ProGuardJoint. Ensure the lapped joints are butted end to end tightly. Fit the plastic bolt and wingnut at the lapped joint. Ensure the wingnut is positioned horizontally.

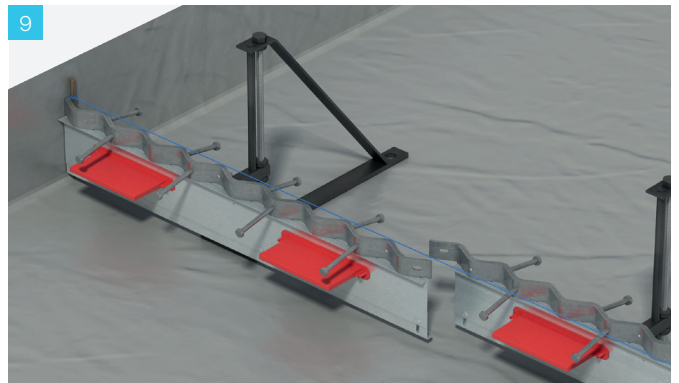

9 Measure final distance and cut ProGuardJoint to suit, allow space for any isolation material required between the slab and the wall/ fixture.

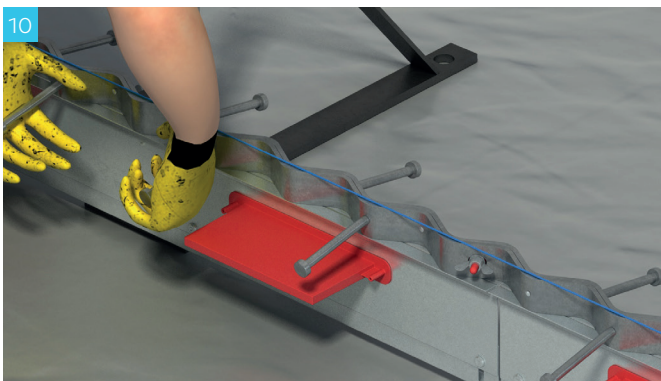

10 Manually position ProGuardJoint in line with string lines.

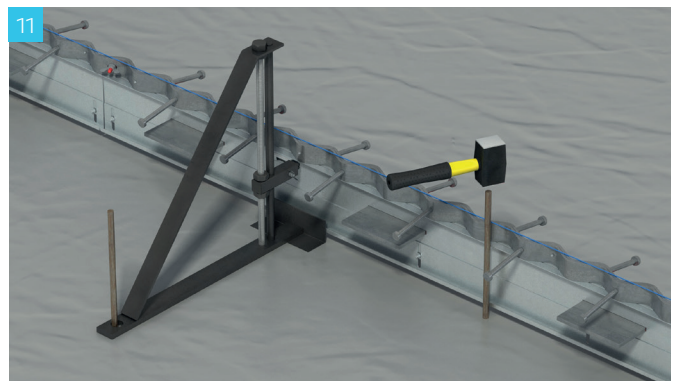

11 Pin the ProGuardJoint Jacks into place and drive the pins behind the ProGuardJoint in between the jacks.

# Installation Guide

## ProGuardJoint

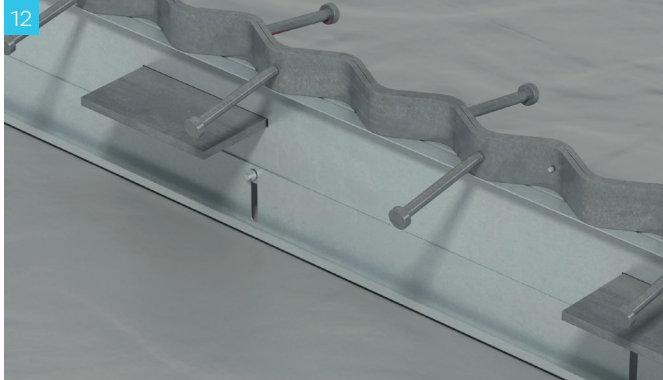

12 Ensure the lower divider plate is pushed fully down to sub-base.

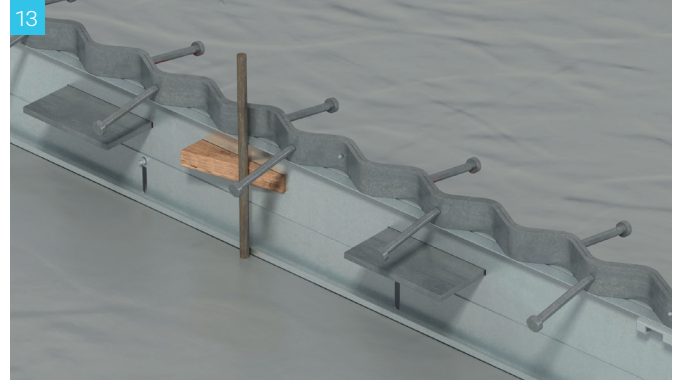

13 Fit the wooden wedges behind the pin to lock the joint in place.

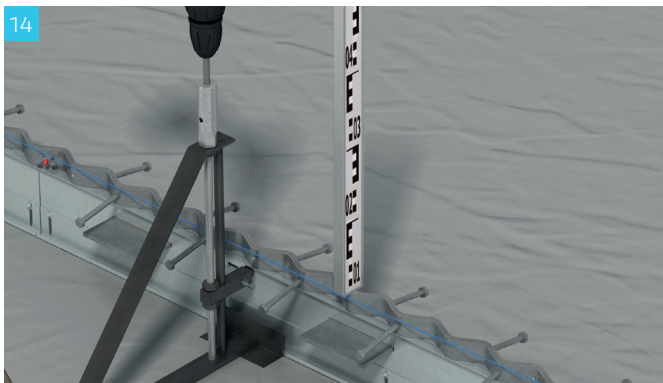

14 Check the height and adjust it using the screw on the jack.

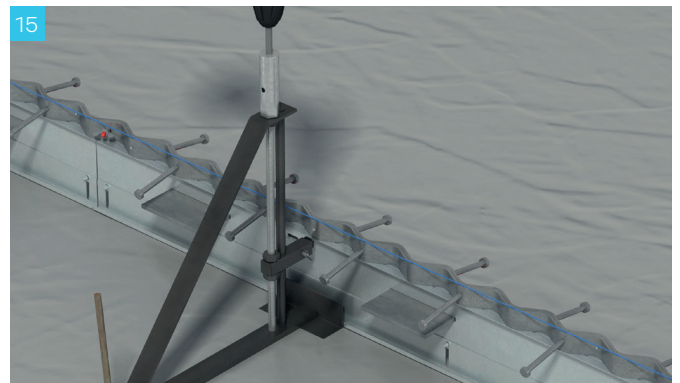

15 Final visual inspection, adjust the position and height of the joint if required.

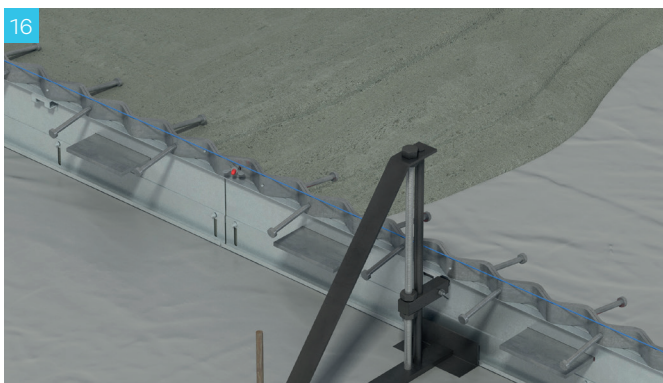

16 Pour the concrete while checking the height and direction of the joint.

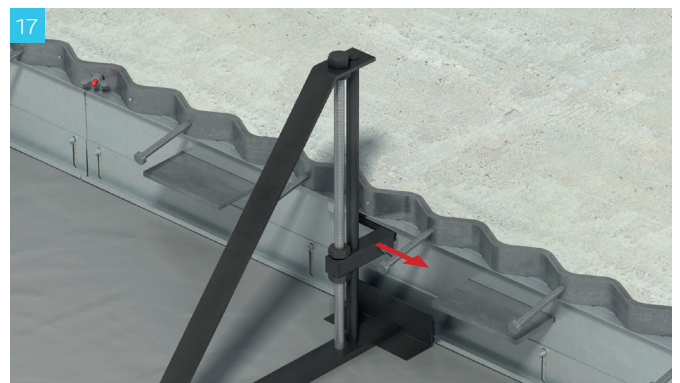

17 Remove the jack by sliding the fixing end out of the bracket.